

A LabVIEW Simulation of the Ideal Gas Transformations

Marinela Ruset,

High School “Stefan Odobleja”, Str. Dorneasca, Nr. 7A, Bucharest,
Romania, E-mail: rusetcristian@yahoo.co.uk

George Bleaja

SC Nova System SRL, Sos. Pantelimon, Nr. 225, Bucharest, Romania,
E-mail: george_bleaja@gmail.com

Abstract. *In this paper, a software program concerning the ideal gas transformations is presented. The isotherm, the isocore and the isobar transformations are simulated using LabVIEW as a programming medium. The LabVIEW windows contain a vessel filled with a gas, a thermometer and a manometer indicated the temperature and the pressure respectively. The three parameters (V , T and P) are connected between them depending on the type of transformation, which is also shown in the window. The time variations of these parameters are recorded on three diagrams (P - V , P - T and V - T) during approx. 60 s.*

Keywords. LabVIEW program, simulation, simple gas transformations

1. Introduction

In the 11th grade of the Romanian high schools, the ideal gas, as a physical model for the real gas, is studied from two points of view.

For the microscopic and macroscopic levels the kinetic molecular theory and the thermodynamic method are respectively used.

This paper presents a new approach of teaching the lesson “Simple transformations of the ideal gas” using the LabVIEW program. LabVIEW can be found in Romanian schools due to an agreement between National Instruments and the Romanian Ministry of Education.

2. Simple transformations of the ideal gas

According to the Romanian Syllabus the isotherm, isocore and isobar transformations are studied. Consequently, the simulations have been done for these three processes only.

2.1. Isotherm transformation

An ideal gas with a constant mass undergoes an isothermal transformation when the temperature remains constant during the thermodynamic process and only the pressure P and volume V change. Under these conditions the $P - V$ dependence is governed by the Boyle-Mariotte law ($PV = \text{const.}$). In Fig. 1 the simulation panel for the isotherm transformation is shown. It contains a vessel with a moving piston, a thermometer and a manometer indicating the volume, the temperature and the pressure of the gas during transformation. All the gas parameters, including the number of mols, the temperature, the pressure and the volume are clearly displayed. The amount of gas, represented by the number of mols, must be initially set. The initial and the final volume, together with three different temperature can be also set. When the “RUN” button is pressed, the gas is slowly compressed or expanded from the initial to final volume. Its pressure changes according to the Boyle-Mariotte law. The transformation is shown on three different diagrams in coordinates P - V , P - T and V - T . According to the three temperatures initially set, three different curves appear on each diagram. In P - T and V - T coordinates these curves are straight lines, whereas in P - V coordinates the curves are hyperbolas. The simulation takes about 1 minute. Then it can be re-started with the same or different parameters.

2.2. Isobar transformation

An isobar transformation of a certain amount of gas occurs when the pressure is kept constant. The gas is heated up or cooled down and the correlation between its temperature and volume is given by Gay-Lussac law ($V/T = \text{const.}$). The simulation panel for isobar transformation is

shown in Fig.2. It is similar to that described at the isotherm transformation except that a heating source has been introduced below the vessel. This time, three different values of pressure can be chosen. The time variations of the process parameters are recorded on the three diagrams for the three set values of pressure. The simulation takes about 1 minute. The curves are straight lines on all diagrams.

2.3. Isocore transformation

During an isocore transformation for a certain amount of the ideal gas, the gas volume is kept constant, whereas the temperature and the pressure change according to the Charles law ($P/T = \text{const.}$). The simulation panel, which is very similar to that corresponding to the isobar transformation, is shown in Fig.3. Since the transformation occurs at a constant volume, three different values of this parameter can be chosen. The simulation takes also about 1 minute and the curves are straight lines on all diagrams.

During the teaching lessons, the values of the three parameters (P, V and T) can be modified and the student understands much better their interdependence according to the corresponding laws of the thermodynamic processes.

3. Simulation program

The LabVIEW application for simulating the simple transformations of the ideal gas contains a main program and three subprograms. Each subprogram calculates and displays the corresponding data for the isotherm, isobar and isocore transformations. The control panels for the three subprograms are those shown in Figs. 1, 2 and 3. Depending on the type of transformation, one parameter (T, P or V) is set and the other two change according to the corresponding law. The number of mols must be always set.

For each panel the following instruments have been used:

- digital thermometer for the temperature display
- digital manometer for pressure display
- a vessel with piston which is used to simulate the compression or expanding of the gas.
- numerical display for the calculated temperature, pressure or volume.
- graphics in P-V, P-T and V-T coordinates.

As an example, the code of the isotherm subprogram is shown in Fig.4. As it can be seen, it contains a main loop, which is executed as long as the "STOP" button is not pressed. In the loop there is a "case" type structure, which imposes that the data calculation to be made at established moments. In this respect the "get date/time in seconds" function is used [1, 2]. For each subprogram there is a similar code.

4. Conclusions

The presentation of this lesson in front of the students was a real success as the simulation of the simple transformation enabled each student to see directly the modification of process parameters depending on the type of thermodynamic process which was studied.

5. Acknowledgements

The work was partially supported by the "Hands on science" project (110157-CP-1-2003-1-PT-COMENIUS-C3).

6. References

- [1] M. Munteanu, B. Logofatu, Virtual instrumentation – LabVIEW, Ed. CREDIS, Bucharest, 2003
- [2] M. Munteanu, B. Logofatu and R. Lincke, Applications of virtual instrumentation – LabVIEW, Ed. CREDIS, Bucharest, 2004

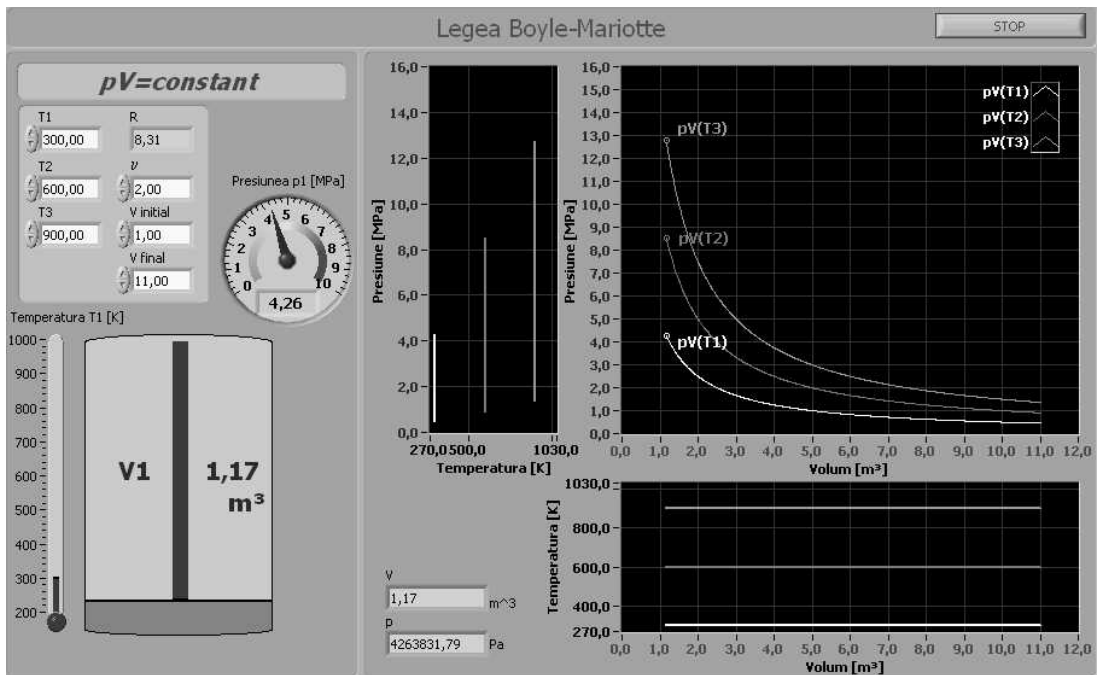

Figure 1. The isotherm simulation panel

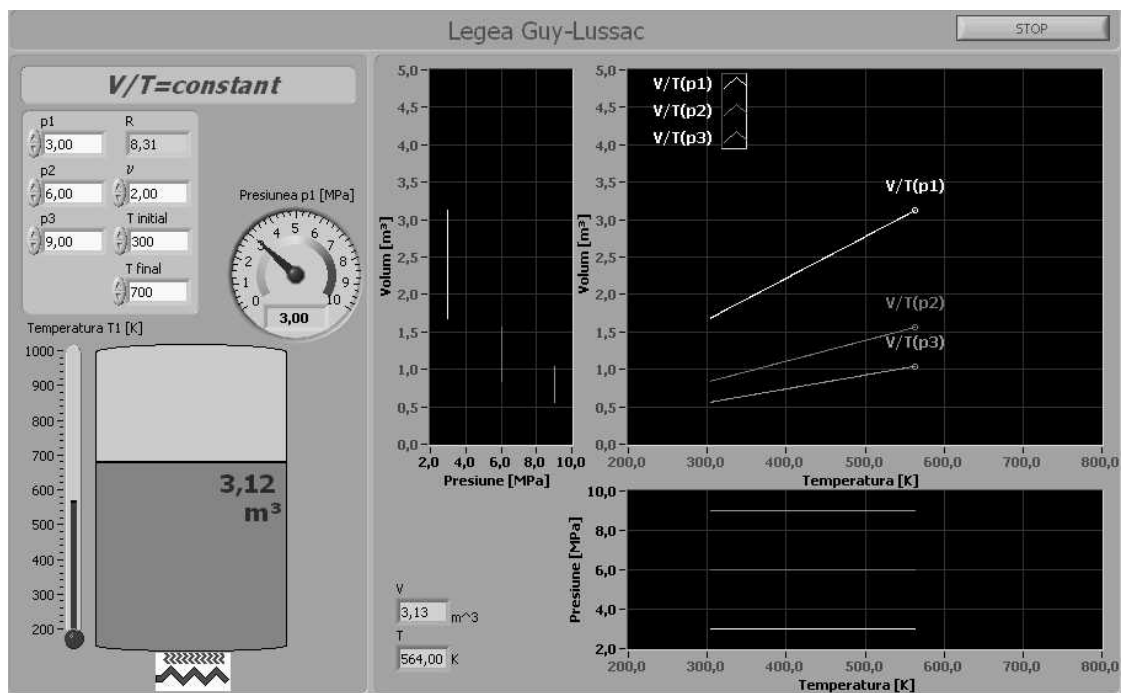

Figure 2. The isobar simulation panel

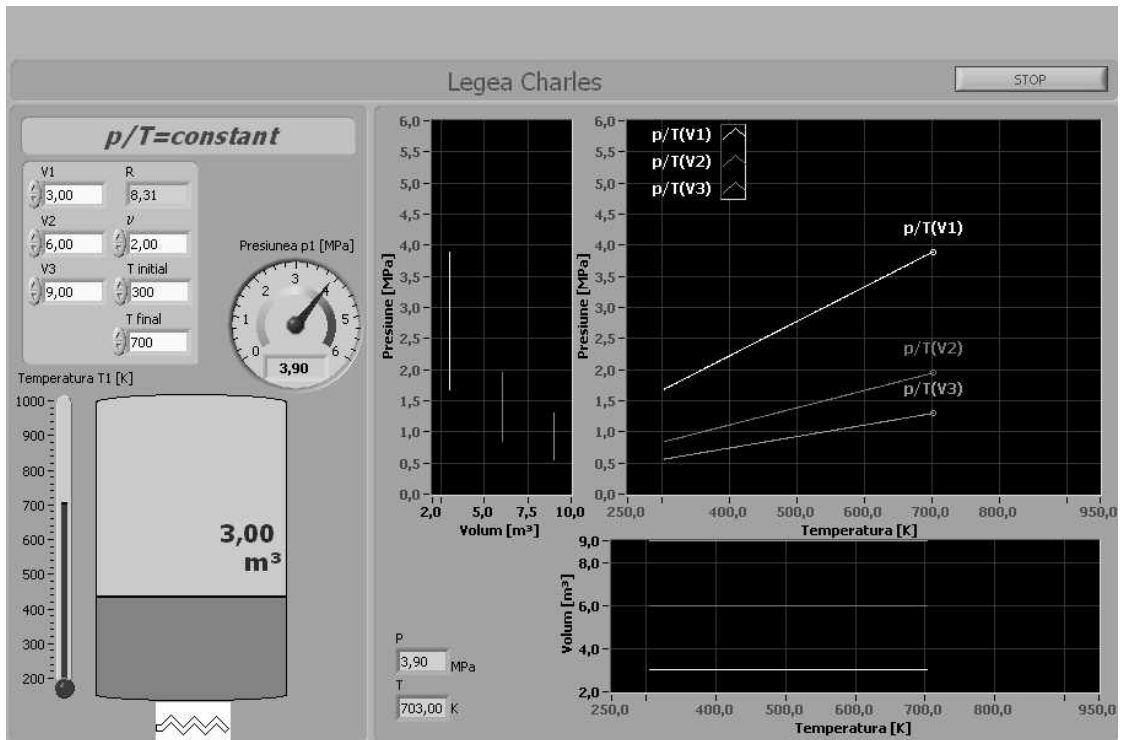

Figure 3. The isocore simulation panel

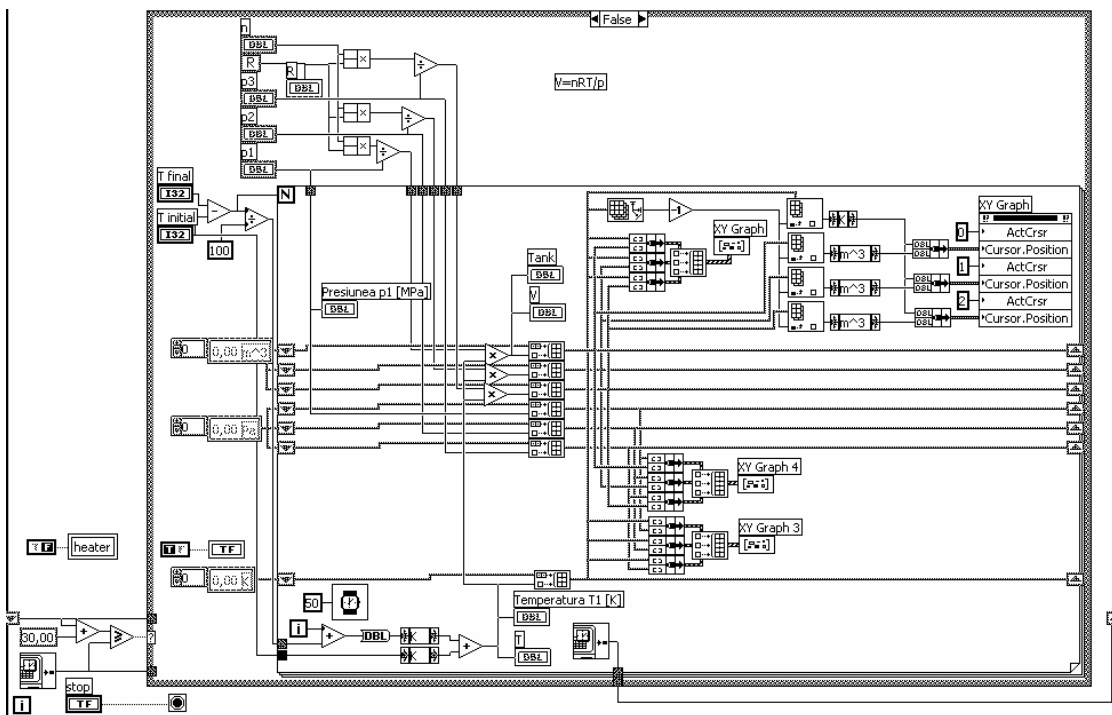

Figure 4. The subprogram code for isotherm transformation